



The future of enterprise social networks: Powering business beyond social collaboration

Joachim Heinz, Director Digital Transformation & Agile Company

J. Boye Aarhus 2015



BOSCH



360,000 associates

Workshop for Precision
Mechanics and
Electrical Engineering



3 associates

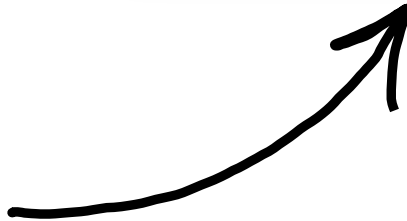

188
6

201
5



BOSCH

Technology as a driving force for industrial development



Steam – 1850



Electricity – 1900

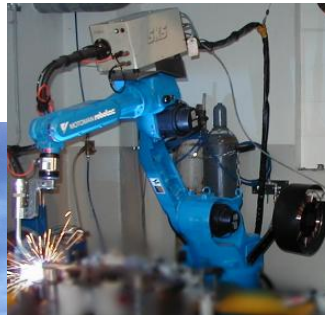

Robotics – 1950

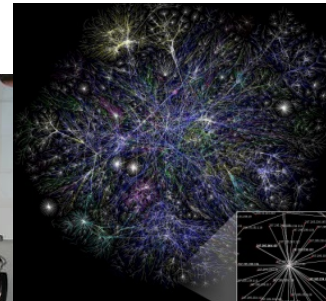

Networking – 1990

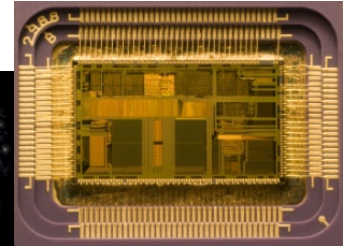

Cloud // mobile data // bandwidth // 3D print // ...

Industrialization

Digitalization



Digital age in plain examples



1965

Rise of the VUCA world

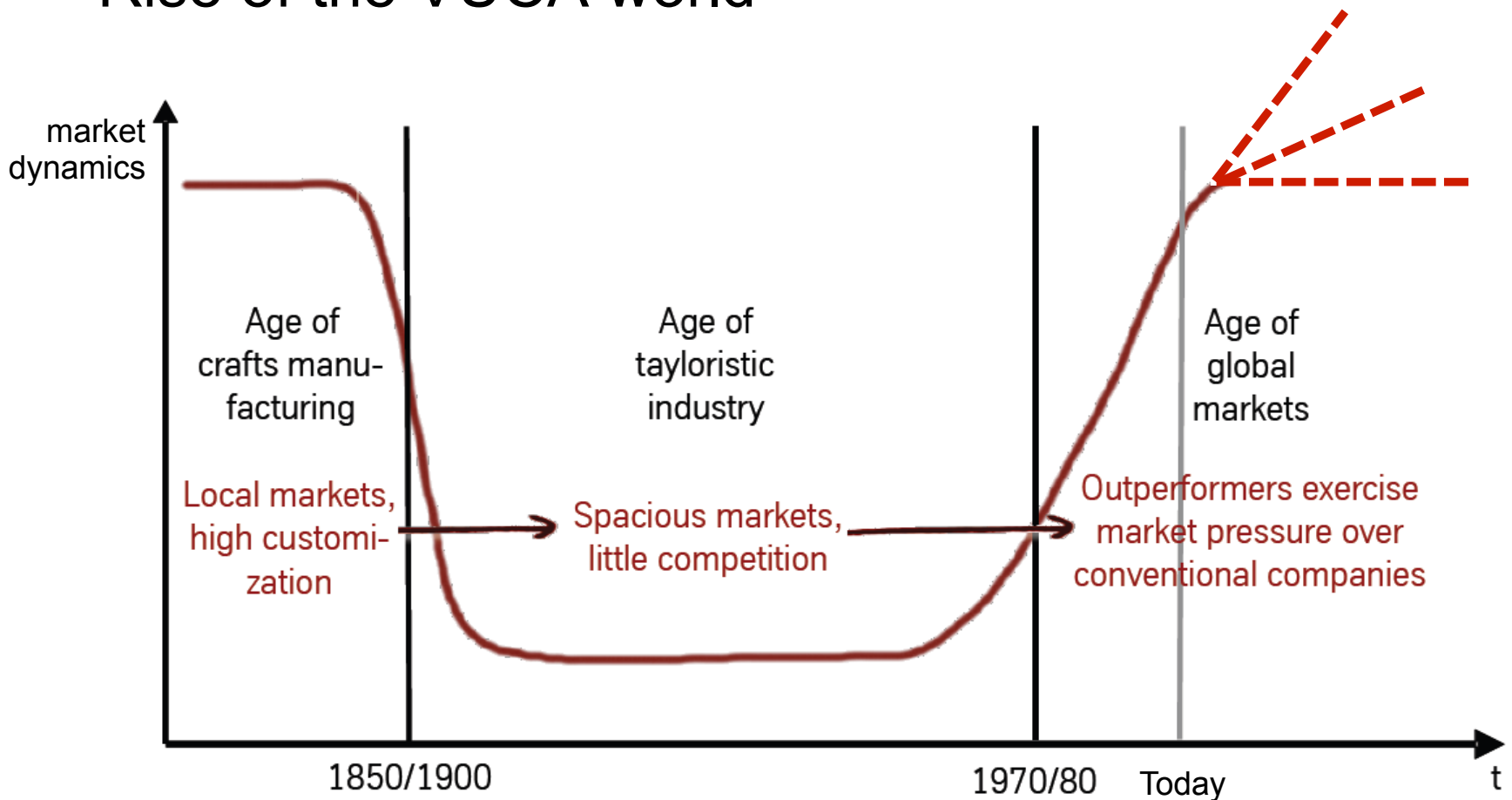

Source: [BetaCodex](#) – Organize for complexity



BOSCH

Digitalization is changing markets and customers

Market leaders



New business models



Start-ups changing value-added chains



Influence on companies

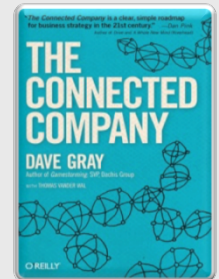
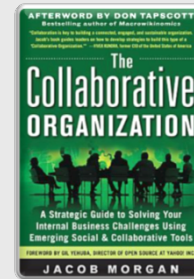

Highly connected company

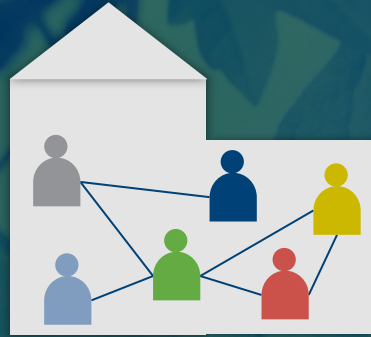

Step 1
“Enterprise2.0”

2012

2013

2014

2015

2016

.....



BOSCH

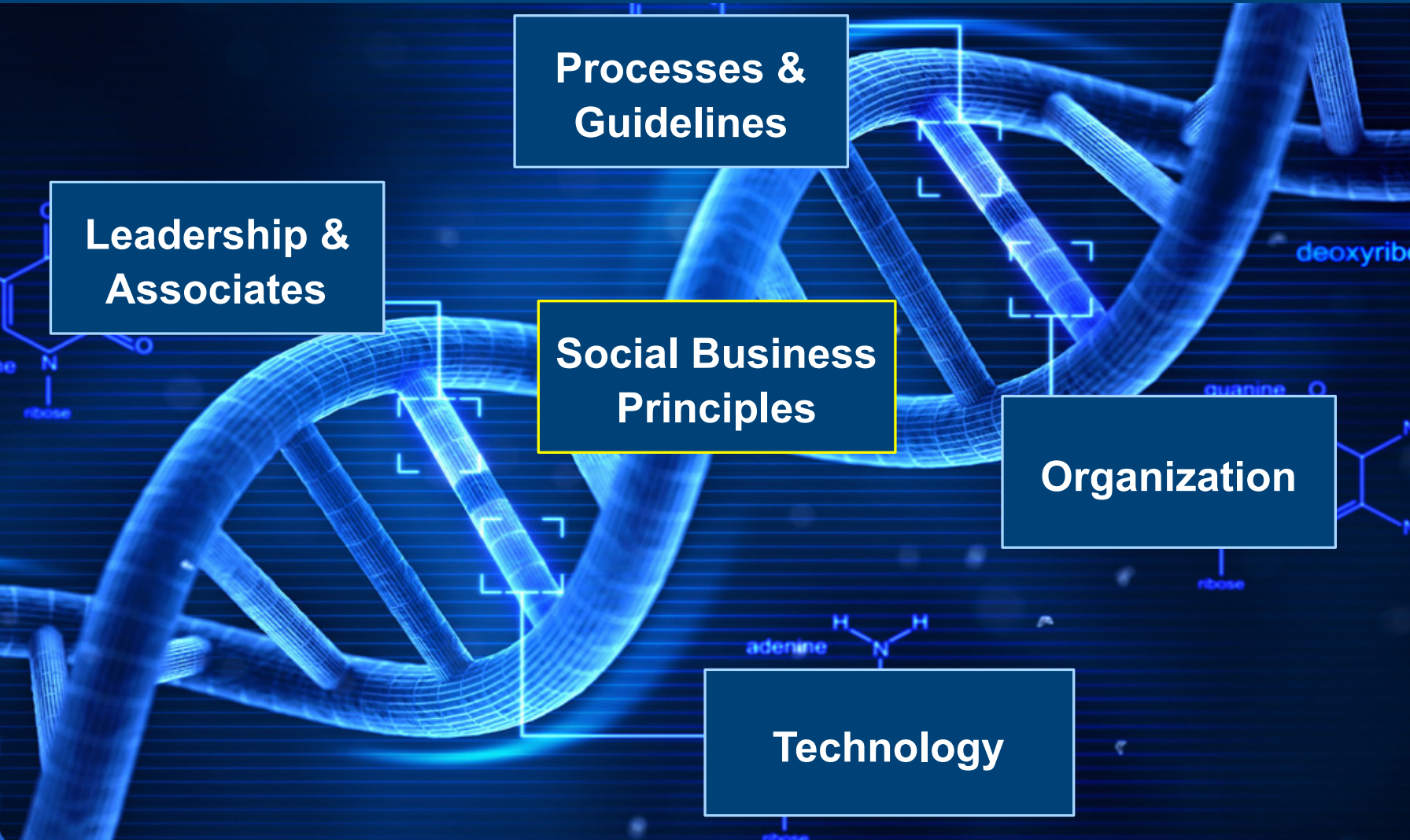

Shifting company culture by hiding button for closed communities #transparency

Start a Community

*Name:

Tags:

Web Address: <https://connect.bosch.com/communities/community/>
 ?

Enter a short name to customize the link, or leave blank.

*Access: **Public** - anyone can join ?
 Moderated - people must request to join ?

Members: Select a role and add people to that role.

Description: 



Thinking in collaboration optimization...

Organizing Meetings

Bosch Connect gives easy access to all colleagues and their schedules. Thus it makes organizing and documenting meetings efficient and transparent.

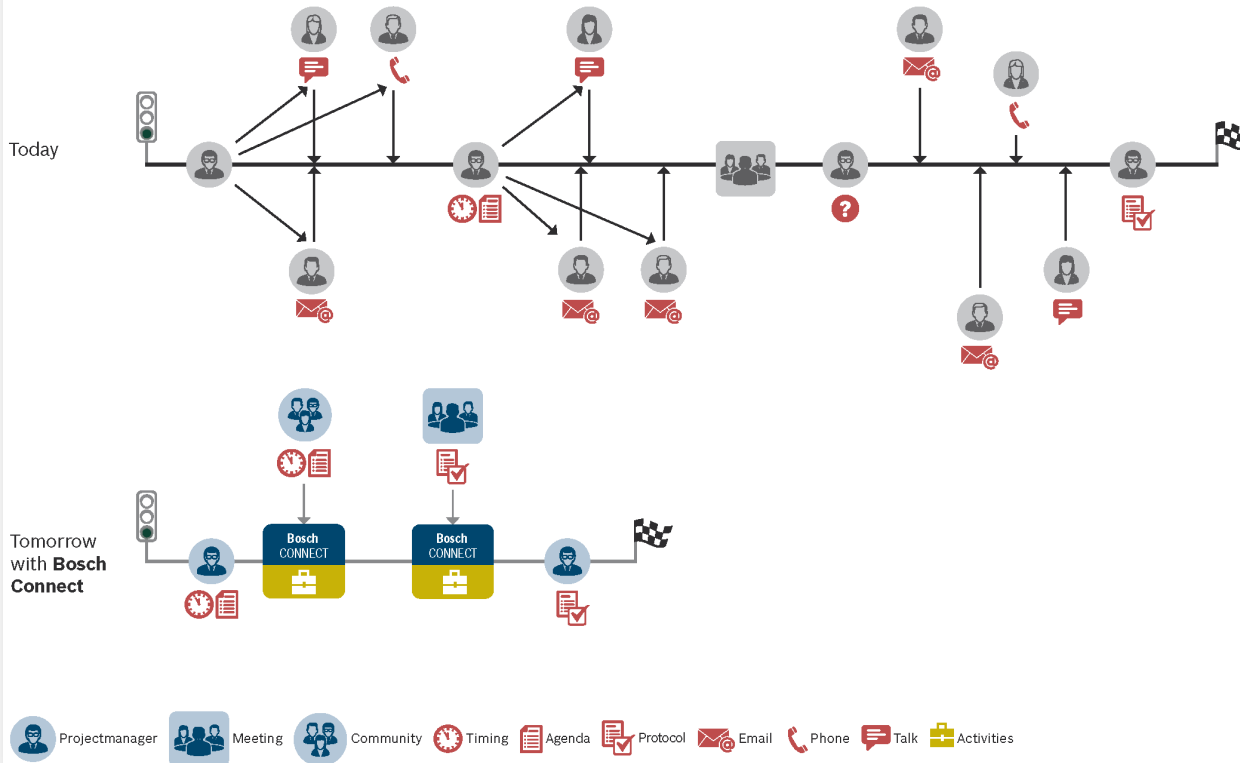

Enhanced social collaboration example

**Objective: Accelerate
“TPZ” core process**

**Ca. 440 colleagues
25 locations**

**Community +
high transparency**

Result:

High level of satisfaction

Significant e-mail reduction

Lean process



BOSCH

One-stop-shop for all relevant information regarding #socbiz: The Experience City

Experience City
explore - learn - share

Community Description

[Bosch Connect Online Course](#) | [Bosch Connect Roadmap](#) | [Bosch Connect New Features](#)

First Steps

- [Getting started guide](#)
- [Understanding Social Business](#)
- [Qualification overview](#)
- [Bosch Connect Apps Overview](#)

E2.0 Roles

- [Associate](#)
- [E2.0 Project Manager](#)
- [Community Manager](#)
- [E2.0 Leader](#)
- [E2.0 Ambassador](#)
- [Social Business Consultant](#)

Support

- [Support forum](#)
- [Bug forum](#)
- [Feature request ideas](#)
- [Tips & tricks](#)
- [FAQ](#)
- [★ Setting up a restricted Community](#)
- [E2.0 Project Managers](#)
- [Community Yellow pages for GB](#)

Experiences

- [Social Business Atlas \(Success Stories\)](#)
- [Experience Exchange](#)

Social Business Library

- [Books](#)
- [Case studies](#)
- [Articles](#)
- [Community types](#)
- [Quick wins](#)
- [Social Business Processes](#)

News

- [Blog news](#)
- [Short status updates](#)
- [Social Business Events](#)

Subcommunities

- [Social Business Library](#)
- [Bosch Connect Feature Re](#)

Spreading the business value add with the #socabiz atlas – interactive map of best-practices

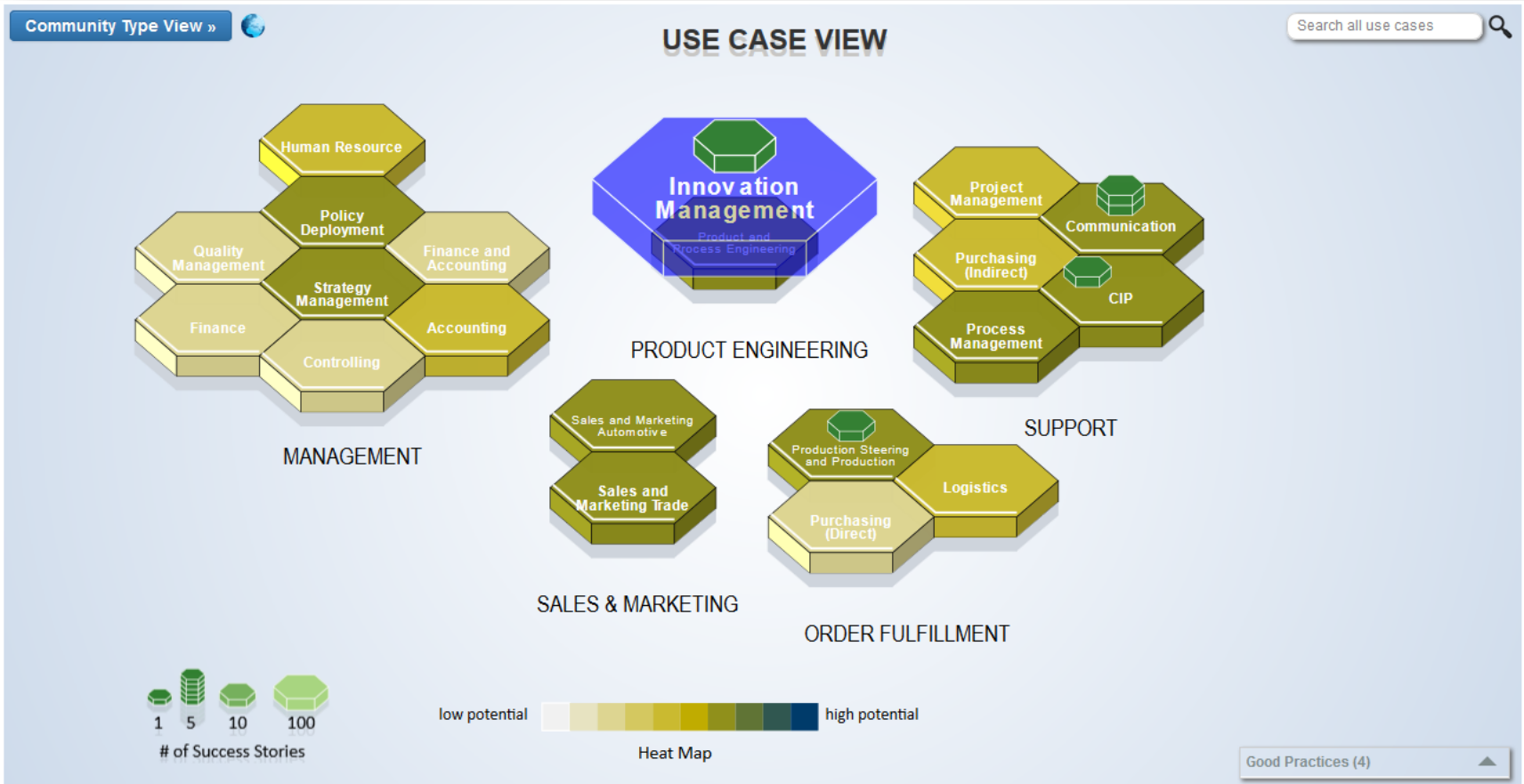



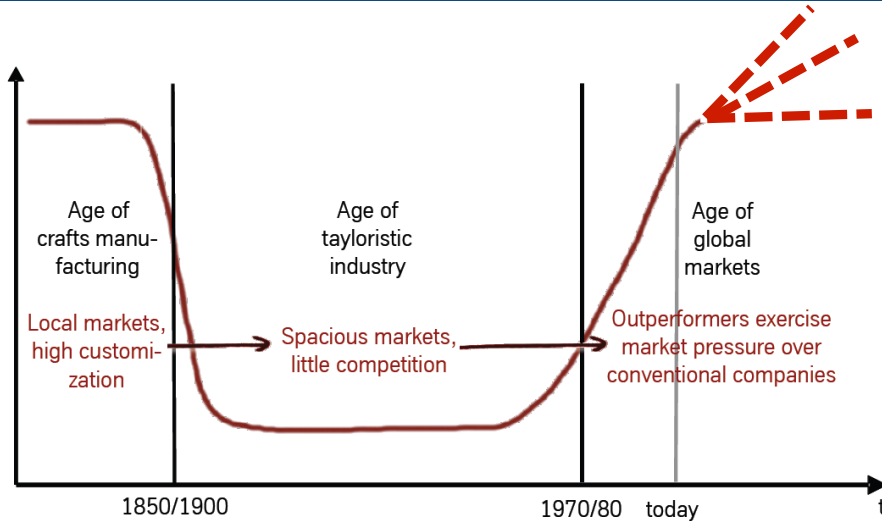

Today's world

Volatile
Uncertain
Complex
Ambiguous

Today's organization

Solid
Hierarchical
Functional
Slow

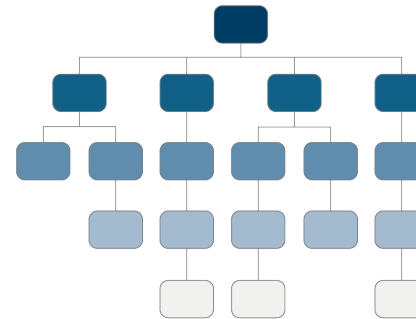

**Highly connected
and
agile company**

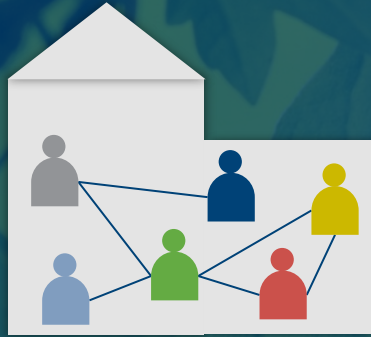

**Step 2
“Agility capabilities”**

**Step 1
“Enterprise2.0”**

2012

2013

2014

2015

2016

.....



BOSCH

Airbnb

Network enables the market place



Firefox

Community-based work

LinkedIn

Network enables expertise localization



KICKSTARTER

Crowd funding for projects



BOSCH

Airbnb
Network enabled

Network is
key driver

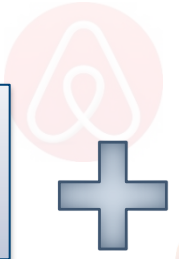

New methods of
business
financing and
staffing

work

LinkedIn
Network enables expertise



**Collaborative
sourcing
within an Enterprise**

ARTER
Crowd funding for projects



Powering agility: ESN to bring together opportunities and people



Business case experiments – Strengthening innovation

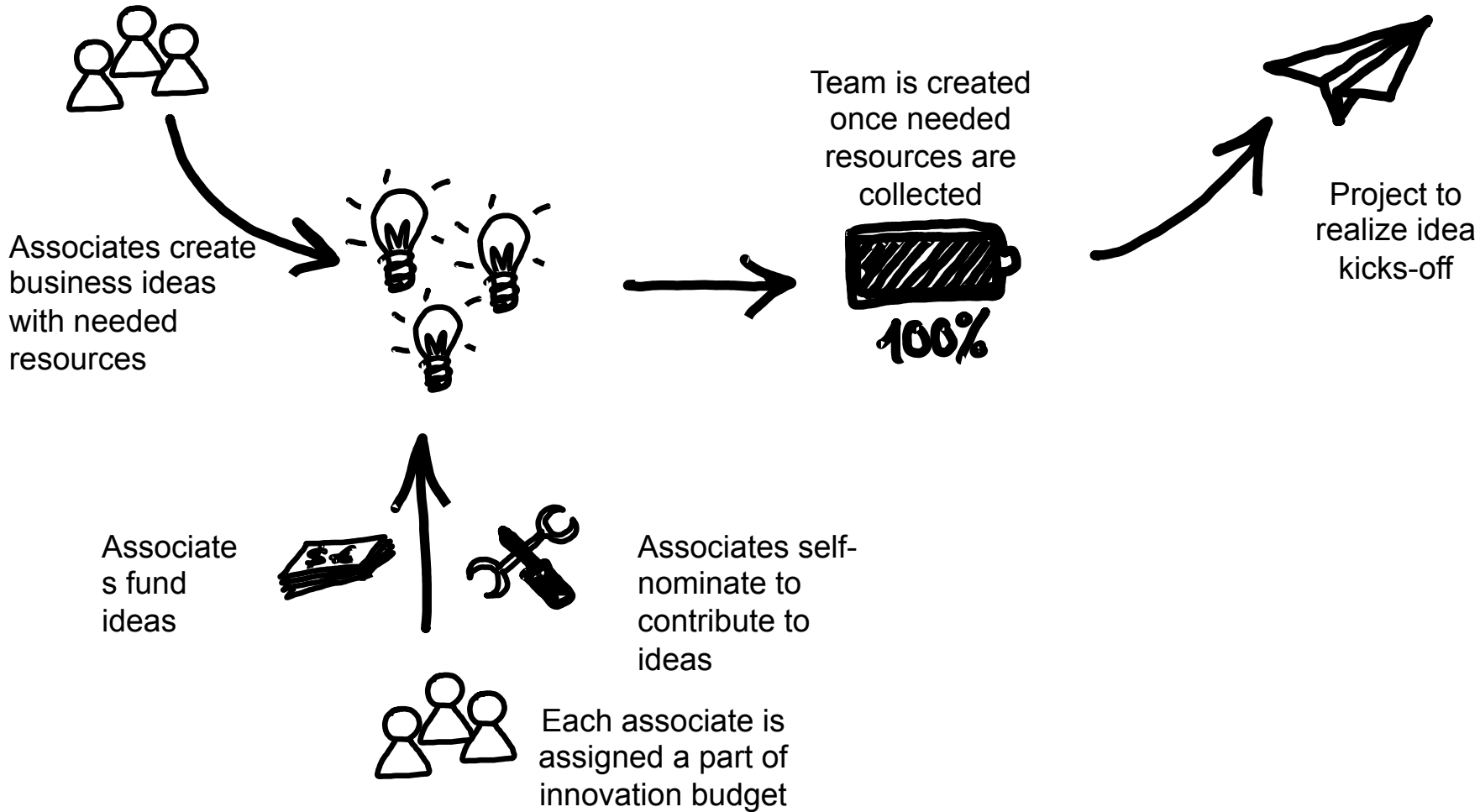

The future of the ESN: Powering new forms of organizing teams means being the backbone for business

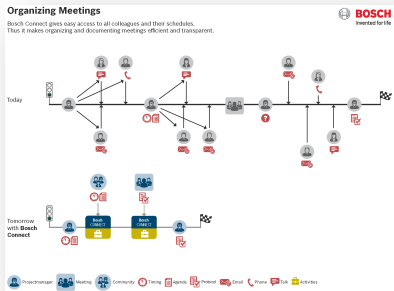

Communication & Collaboration

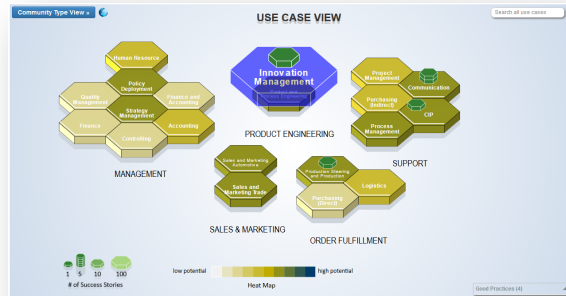

Learning & Sharing

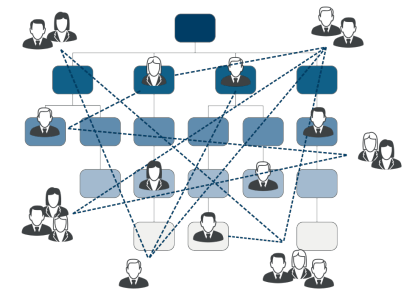

Connected Teams



Ending the ROI discussion:

The ESN will be the future backbone of organizations – and thus a prerequisite for business operations.



THANK YOU!



Joachim Heinz
+49 (0)172 1588805

joachim.heinz@de.bosch.com
@joachimheinz
<https://de.linkedin.com/in/joachimheinz>



BOSCH